

Model Description
North American Animal Disease Spread Model 3.1

Version 1.1.2
October 25, 2010

NAADSM Development Team
Neil Harvey and Aaron Reeves, editors

Contents of appendix A

Contents of appendix A	A-3
A1. Introduction	A-5
Keywords	A-5
A2. Basics	A-5
A3. Disease	A-6
Disease parameters.....	A-7
A4. Spread	A-8
A4.1. Direct contact spread.....	A-8
Parameters for direct contact spread	A-13
Examples of direct contact spread	A-14
Example 1	A-14
Example 2	A-14
Example 3	A-14
Example 4	A-15
Example 5	A-15
Example 6	A-15
Example 7	A-15
A4.2. Indirect contact spread	A-16
Parameters for indirect contact spread.....	A-16
A4.3. Airborne spread.....	A-16
Parameters for airborne spread	A-17
A5. Detection	A-18
Detection parameters	A-19
A6. Surveillance	A-20
A6.1. Trace surveillance	A-20
Trace surveillance parameters	A-20
A7. Control measures	A-21
A7.1. Quarantine.....	A-22
A7.2. Destruction	A-22
Destruction parameters	A-22
A7.2.1. Destruction capacity.....	A-23
A7.2.2. Destruction priorities.....	A-23
Examples of destruction priorities	A-24
A7.3. Vaccination	A-25
Vaccination program parameters	A-26
A7.3.1. Initiation of a vaccination program.....	A-26
A7.3.2. Vaccination capacity	A-26
A7.3.3. Vaccination priorities.....	A-27
A7.3.4. Minimum time between vaccinations	A-27
A7.4. Zones.....	A-28

Appendix A. *NAADSM* model description

Zone parameters.....	A-28
A8. Biological effects of vaccination	A-30
Parameters for effects of vaccination.....	A-30
A9. Priorities of action.....	A-31
A10. Costs	A-32
A10.1. Costs associated with destruction	A-32
Parameters for destruction costs	A-32
A10.2. Costs associated with vaccination.....	A-32
Parameters for vaccination costs.....	A-33
A10.3. Costs associated with zone surveillance	A-33
Parameters for surveillance costs.....	A-34

A1. Introduction

This document is intended to be a plain-language description of the simulation model implemented in the *North American Animal Disease Spread Model (NAADSM)* version 3.1. Its purpose is to facilitate agreement among current team members on details of the model, to provide a basis for functional testing, and to provide model users and future team members with a complete but accessible description of the model.

The description is based on papers by Schoenbaum and Disney¹ and Harvey *et al.*²; the document *SpreadModel Version 3.0 Diagrams and pseudocoding* by Mark A. Schoenbaum and Francisco Zagmutt-Vergara; observations of *SpreadModel* v2.14 and beta versions of 3.0; and discussions with the project team.

Keywords

herd-level stochastic spatial state-transition simulation

A2. Basics

A collection of animals, called a “unit,” is the basis of the simulation. A unit has a production type, size, location, and disease state. The production type may be a single kind of livestock (*e.g.*, “dairy cattle”) or a mixed type (*e.g.*, “cattle and sheep”). Figure A2-1 shows the states a unit may be in and possible transitions among them.

The simulation proceeds in time steps of one day. Each day units may be affected by biological processes happening in the animals (*e.g.*, the natural progress of the disease), processes happening in the environment (*e.g.*, airborne spread), and/or human actions (*e.g.*, detection, vaccination, and destruction). The “model” is the sum of these processes and actions.

¹ Schoenbaum, M.A., Disney, W.T., 2003. Modeling alternative mitigation strategies for a hypothetical outbreak of foot-and-mouth disease in the United States. *Prev. Vet. Med.* 58, 25–52.

² Harvey, N., Reeves, A., Schoenbaum, M.A., Zagmutt-Vergara, F.J., Dubé, C., Hill, A.E., Corso, B.A., McNab, W.B., Cartwright, C.I., Salman, M.D., *in press*. The *North American Animal Disease Spread Model*: A description of a simulation model for use as an aid in the decision-making process. *Prev. Vet. Med.*

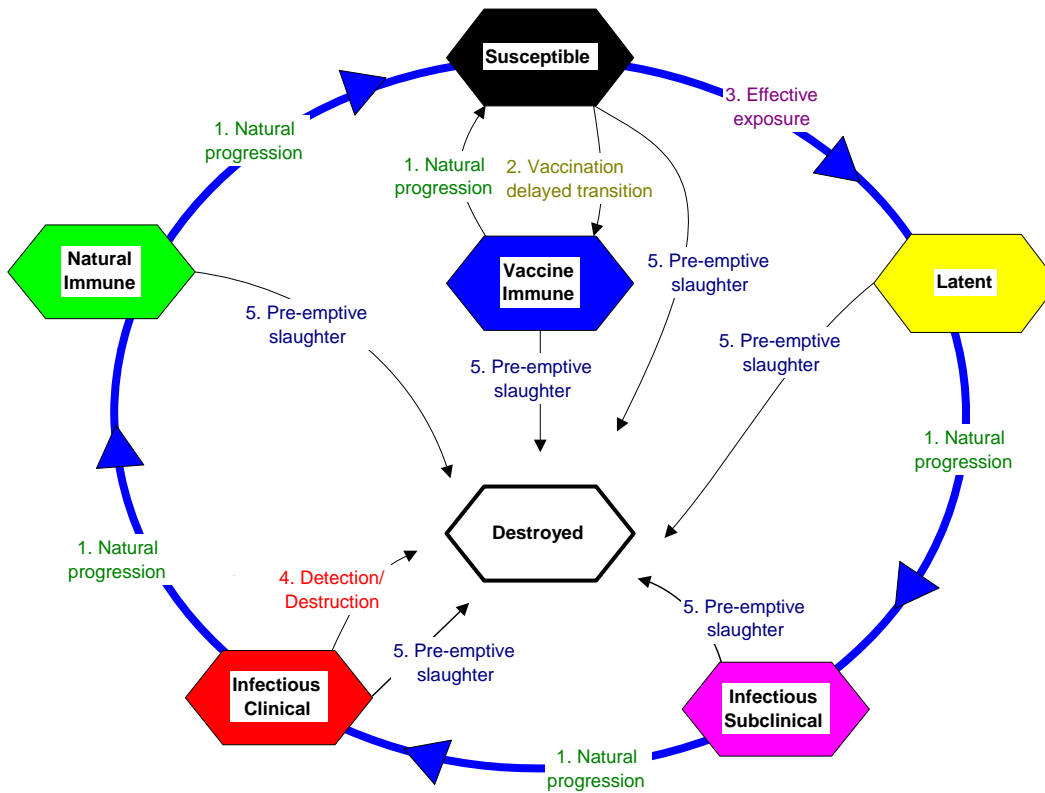

Figure A2-1. States and transitions

A3. Disease

When a Susceptible unit is infected, it becomes Latent. The infection progresses in the unit from Latent to Infectious Subclinical (shedding agent without visible signs of disease), to Infectious Clinical (shedding agent with visible signs of disease), to Natural Immune, and back to the Susceptible state. Probability functions characterize the length of the periods and this length is determined stochastically for each new infection. The disease is never fatal: that is, all infected units will eventually return to Susceptible unless destroyed. If time-frames for simulations are long, a particular unit may progress through the infected states more than once.

A unit can spend zero time in a state. For example, the parameter for time spent as Infectious Subclinical can be zero. In that case, units will change directly from Latent to Infectious Clinical. A unit undergoes its first transition state change on the day immediately following its infection.

While in the Latent, Infectious Subclinical, and Infectious Clinical states, a chart may be used to determine the prevalence, or proportion of animals infected, on a given day. The chart is stretched to cover the total number of days spent in these states, and the





prevalence value for a particular day is obtained by interpolating at the middle of that day (Figure A3-1). The use of prevalence charts is optional.

Attempting to infect a unit that is not Susceptible has no effect.

If two units are at the same location, infecting one does not automatically infect the other.

Disease parameters

Parameters specified for each production type:

- latent period (days) ¹
- infectious subclinical period (days) 
- infectious clinical period (days) 
- natural immune period (days) 
- prevalence (0-1) vs. time (optional) ²

The parameters are given separately for each production type. That is, the duration of the disease stages can be different for cattle, pigs, *etc.*

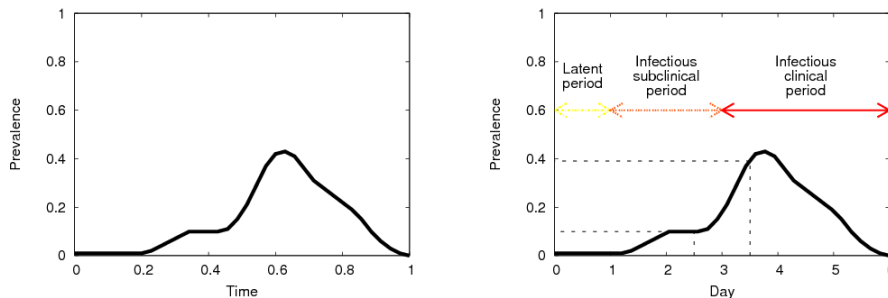



Figure A3-1. Example of a prevalence chart (left) stretched to fit 6 days in diseased states (right). The values for day 3 and day 4 are interpolated as shown.

¹  indicates a parameter that is given as a probability density function.
²  indicates a parameter that is given as a relational chart.

A4. Spread

A4.1. Direct contact spread

The simulation of direct contact – movement of animals among units – works as follows:

On each day,

1. Look up a multiplier to adjust the rate of movement of animals based on the number of days since the first detection of the disease. Use this multiplier to scale the movement rate; call the result k . This approximates applying movement-controls over the course of an infection spreading through the population of units.
2. For each unit A ,
 - (a) Check whether A can be the source of an infection. That is, is it Latent, Infectious Subclinical, or Infectious Clinical, and not quarantined?¹ (Infectious Clinical is always a source. Latent and Infectious Subclinical are optionally a source.)
 - (b) If A cannot be a source, go on to the next unit.
 - (c) If using fixed movement, the number of shipments $N = [(\text{day}+1) \times k] - [\text{day} \times k]$. Otherwise, sample N from a Poisson distribution whose mean is k . (k is calculated in step 1 above.)
 - (d) Create N shipments from A .
3. For each shipment,
 - (a) Make a list of units that can be the recipient of a contact, that is, those that are not Destroyed or quarantined or are the source.
 - (b) If the list is empty, drop this shipment. No exposure is recorded; go on to the next shipment.
 - (c) Sample a number, *distance*, from the movement distance distribution.
 - (d) From the list, choose the unit B whose distance from the source is closest to *distance*. If several possible recipients are the same distance from the source,
 - i. Eliminate the ones where contact is forbidden by zone movement rules. If that eliminates all of them, drop this shipment.
 - ii. Choose one randomly, giving preference to larger units (a unit with twice as many animals is twice as likely to be chosen).
 - (e) If movement from A to B is forbidden by zone movement rules (see below), drop this shipment.
 - (f) If B is not Susceptible, the shipment has no effect on the disease state but is recorded as an exposure; go on to the next shipment.
 - (g) If a within-unit prevalence chart has been specified for the source unit production type, set $P =$ prevalence in source unit. Otherwise, set $P =$ probability of infection given exposure.

¹ See section A7.1. Quarantine for a description of quarantine.

- (h) Generate a random number r in $[0,1)$, that is, from 0 up to but not including 1.
- (i) If $r < P$, turn B Latent after a shipping delay.

These steps are also illustrated as a flowchart in Figure A4-1, and examples are shown below.

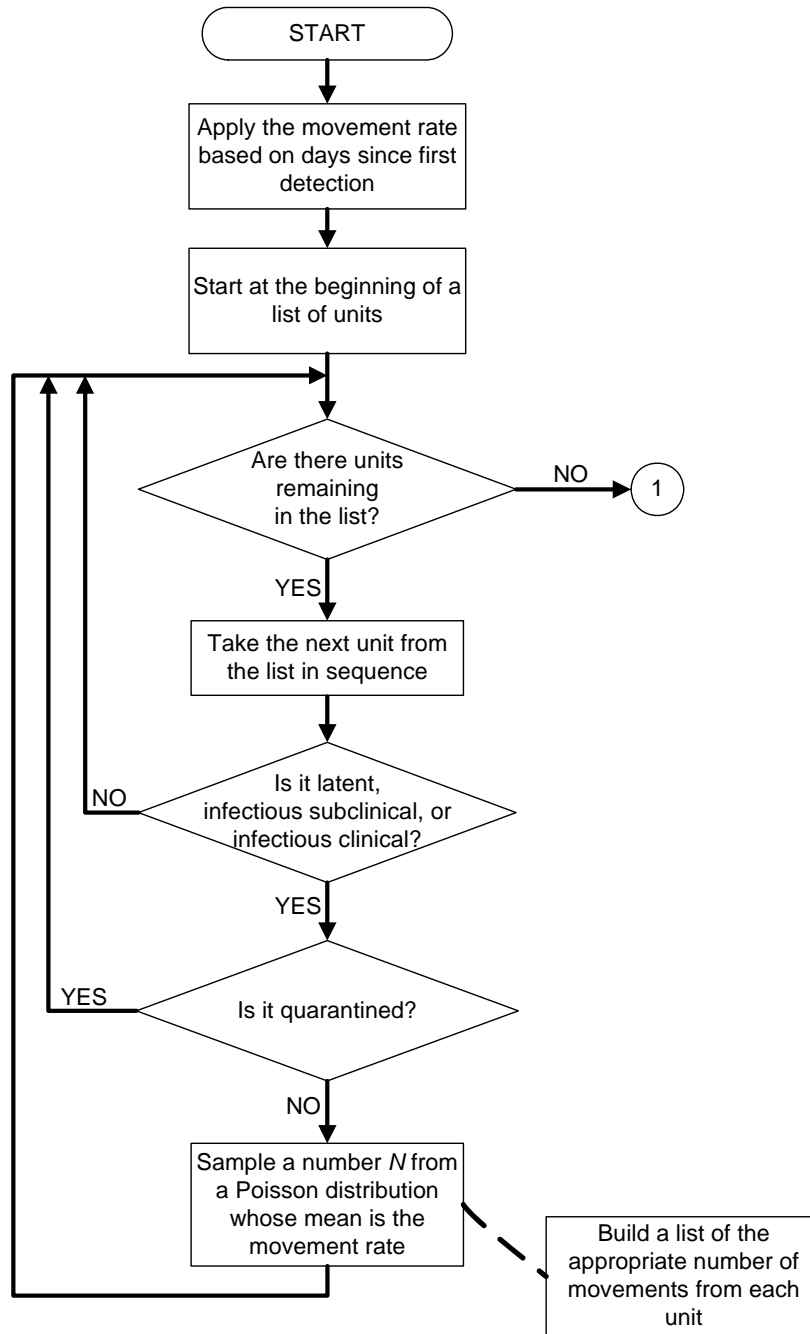

Figure A4-1: Generating direct contacts. The number in the circle links to the continued flowchart on the next page.

Appendix A. NAADSM model description

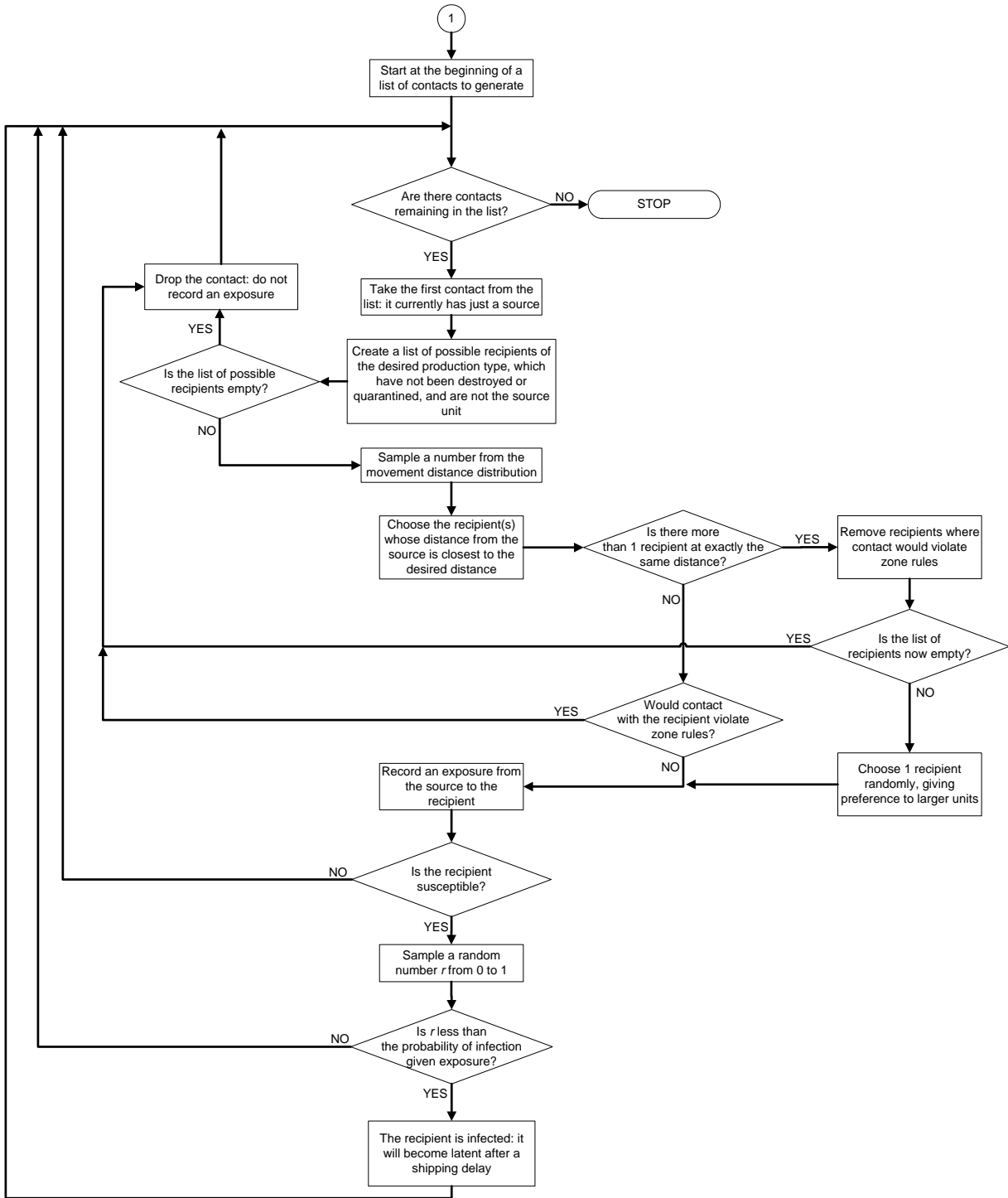

Figure A4-1 (cont'd): Generating direct contacts. The number in the circle continues the flowchart on the previous page.

In its regular operation, the model chooses the number of shipments each day stochastically. For example, if the mean movement rate parameter is 1, a unit may send out no shipments on some days, and 2 shipments on others, but the mean number of shipments over the long run will be 1 per day. The “fixed movement” option, by contrast, provides a predictable, deterministic number of shipments each day. For example, if the movement rate is 1, fixed movement will produce exactly 1 shipment each day. If the movement rate is 0.5, there will be a shipment every second day. Both the regular and “fixed movement” options will produce the same mean shipment rate over the long run.

Direct contact between units is forbidden if either the source unit or receiving unit is quarantined (see section A7.1. Quarantine). Direct and indirect contact between units can also be forbidden if the source unit and receiving unit are in physically separated foci of the same zone, or if the source unit is in a zone of a higher surveillance level than the receiving unit (figures A4-2 to A4-4; see also section A7.4. Zones).



Figure A4-2. Movement inside a zone may be allowed, but movement between physically separated foci of the same zone is not.



Figure A4-3. Movement from a zone to an adjacent zone of a higher surveillance level is allowed, but not vice-versa.

Appendix A. NAADSM model description

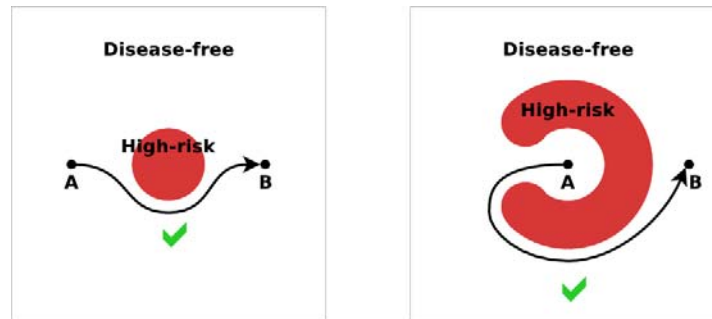

Figure A4-4. Movement that would cross a zone of a higher surveillance level “as the crow flies” but where a “detour” exists, is allowed.

The progress of the disease in the receiving unit starts at Latent, with the duration of each stage of the disease chosen stochastically, regardless of whether the shipping unit was Latent, Infectious Subclinical, or Infectious Clinical. A unit that receives Infectious Clinical animals could technically be regarded as immediately Infectious Clinical (able to infect other units by airborne spread and indirect contact, and detectable by a farmer or attending veterinarian) but starting the receiving herd at Latent reflects the fact that *most* of the animals in the receiving unit have to progress through the earlier disease-stages. The disease-state is an attribute of the unit as a whole rather than a direct reflection of the state of a particular animal in the unit.

Direct contacts (even those that do not result in a new infection) are recorded and can be discovered later during trace-investigations.

The size of a shipment is not considered, and the number of animals in each unit does not change during the simulation.

The distance between lat_1, lon_1 and lat_2, lon_2 is approximated as:



$$y = lat_2 - lat_1$$

$$x = (lon_2 - lon_1) \cdot \cos(lat_1)$$

$$d = \frac{c}{360} \cdot \sqrt{x^2 + y^2}$$

where c = the circumference of the earth.

Parameters for direct contact spread***Parameters for each combination of source production type and recipient production type:***

- Mean rate of movement (recipient-units for shipments per source-unit per day)
- use fixed movement (yes/no)
- movement distance (km) 
- shipping delay (days) 
- probability of infection given exposure
- movement rate multiplier vs. days since the first detection (for units not inside a zone focus) 

Parameters for each combination of source production type and zone:

- movement rate multiplier vs. days since the first detection (for units inside a zone focus) 

When more than one production-type is considered, the above parameters are specified for each pairing of one production-type with another. Consider the production-types “Beef” and “Dairy”, referring to herds of beef cattle and dairy cattle. You specify the most important pairings of these production-types with regard to direct-contact parameters. For example: “Beef” to “Beef”, “Beef” to “Dairy”, “Dairy” to “Beef”, and “Dairy” to “Dairy” are the possible pairings of these production-types. Separate parameters are specified for each of these pairs since the direct-contact among different production-type may vary.

Note that parameters are separate for movement in each direction between each pair of production-types. That is, the parameters for movement from “Beef” to “Dairy” can be different from the parameters for movement from “Dairy” to “Beef”, and the parameters for movement from “Beef” to say “Pigs” can be different again.

If parameters are given for movements from “Beef” to “Beef” and from “Beef” to “Dairy”, the number of shipments a “Beef” cattle herd *A* sends to “Beef” cattle herds on a particular day and the number of shipments *A* sends to “Dairy” cattle herds on the same day are independent.

Shipping animals from a Latent, Infectious Subclinical, or Infectious Clinical unit to a Natural Immune or Vaccine Immune unit has no effect on the disease-stage of the recipient unit. Shipping animals from a unit in a more advanced disease stage to a unit in a less advanced disease stage (e.g., from an Infectious Clinical unit to a Latent unit) also has no effect.

Examples of direct contact spread

Example 1

As an example, suppose that shipments are being generated from “Beef” to “Dairy” units. In step 3 above, shipments are being generated from a particular source unit of production type “Beef”. Other units in the population are:

- Unit 1. Swine unit, Susceptible, not quarantined, 25 km away
- Unit 2. Dairy unit, Susceptible, not quarantined, 40 km away
- Unit 3. Dairy unit, Susceptible, not quarantined, 300 km away

In step 3a, the possible recipients are units 2 and 3. (Unit 1 is excluded because shipments from Beef units to Swine units are separate from and independent of shipments from Beef units to Dairy units. See notes on multiple production types below.) Suppose that in step 3c, the value “30 km” is sampled from the movement distance distribution. Unit 2 will be chosen because 40 km is closer than 300 km to the desired movement distance of 30 km.

Example 2

Suppose that the other units were instead:

- Unit 1. Swine unit, Susceptible, not quarantined, 25 km away
- Unit 2. Dairy unit, Infectious Clinical, not quarantined, 40 km away
- Unit 3. Dairy unit, Susceptible, not quarantined, 300 km away

In this case, unit 2 will still be chosen. The fact that unit 2 is already diseased does not affect the decision.

Example 3

An example with a Destroyed unit:

- Unit 1. Swine unit, Susceptible, not quarantined, 25 km away
- Unit 2. Dairy unit, Destroyed, 40 km away
- Unit 3. Dairy unit, Susceptible, not quarantined, 300 km away

In this case, the only possible recipient is unit 3, so it will be chosen. It does not matter that 300 km is much farther than the desired movement distance of 30 km, only that *of all possible recipients* (in this case there is only one), 300 km is the best match.

Example 4

An example where there are *no* possible recipients:

Unit 1. Swine unit, Susceptible, not quarantined, 25 km away

Unit 2. Dairy unit, Destroyed, 40 km away

Unit 3. Dairy unit, Susceptible, quarantined, 300 km away

In this case, the shipment will be “dropped” because there is no possible recipient unit in the population.

The following examples illustrate how zone rules can affect contacts. Suppose the source “Beef” unit is inside a zone focus. Other units in the population are:

Unit 1. Dairy, Susceptible, quarantined, inside the same zone focus, 30 km away

Unit 2. Dairy, Susceptible, not quarantined, inside the same zone focus, 31 km away

Unit 3. Dairy, Susceptible, not quarantined, outside the zone focus, 25 km away

Example 5

Suppose we decide, again, to generate a 30 km shipment. Although unit 1 is exactly 30 km away, it will not be considered because it is quarantined (it is excluded in step 3a).

Unit 2 will be chosen because 31 km is closest to 30 km. Unit 2 is inside the same zone focus as the source, so the shipment is not blocked by zone rules.

Example 6

Suppose instead that the distances of units 2 and 3 were exchanged:

Unit 1. Dairy, Susceptible, quarantined, inside the same zone focus, 30 km away

Unit 2. Dairy, Susceptible, not quarantined, inside the same zone focus, 25 km away

Unit 3. Dairy, Susceptible, not quarantined, outside the zone focus, 31 km away

Again, unit 1 is excluded because it is quarantined. Unit 3 would be chosen because 31 km is closest to 30 km. However, unit 3 is outside the zone focus that the source is in, so the shipment is blocked by zone rules and dropped.

Example 7

A final example:

Unit 1. Dairy, Susceptible, quarantined, inside the same zone focus, 30 km away

Unit 2. Dairy, Susceptible, not quarantined, inside the same zone focus, 30 km away

Unit 3. Dairy, Susceptible, not quarantined, outside the zone focus, 30 km away

Again, unit 1 is excluded because it is quarantined. Units 2 and 3 both match the chosen shipment distance of 30 km. According to step 3d, we can eliminate the contact that would be blocked by zone rules (unit 3), and so we choose unit 2.



A4.2. Indirect contact spread

Indirect contact – movement of people, materials, vehicles, equipment, animal products, etc among units – is simulated in the same manner as direct contact, except that only Infectious Subclinical and Infectious Clinical units, not Latent units, can be the source of infection. The parameters for indirect contact are similar to but independent from those for direct contact. Indirect contact is not affected by within-unit prevalence.

Indirect contacts can be discovered later during trace-investigations.

Parameters for indirect contact spread

Parameters for each combination of source production type and recipient production type:

- Mean rate of movement (recipient-units for shipments per source-unit per day)
- use fixed movement (yes/no)
- movement distance (km) 
- shipping delay (days) 
- probability of infection given exposure
- movement rate multiplier vs. days since the first detection (for units not inside a zone focus) 

Parameters for each combination of source production type and zone:

- movement rate multiplier vs. days since the first detection (for units inside a zone focus) 

A4.3. Airborne spread

The simulation of airborne spread works as follows:

On each day,

1. For each unit *A*,
 - (a) Check whether *A* can be the source of an infection. That is, is it Infectious Subclinical or Infectious Clinical?
 - (b) If *A* cannot be a source, go on to the next unit.
 - (c) For each other unit *B*,
 - i. Check whether *B* can be the target of an infection. That is, is it Susceptible, is the distance from *A* to *B* < the maximum

- distance of spread, and is the direction from A to B inside the wind direction range?
- ii. If B cannot be a target, go on to the next unit.
 - iii. If using linear dropoff, compute the probability of infection $P = (\text{prevalence in } A) \times \text{HerdSizeFactor}(A) \times (\text{probability of infection at 1 km}) \times \text{DistanceFactor}(A,B) \times \text{HerdSizeFactor}(B)$
 If using exponential dropoff,
 $P = (\text{prevalence in } A) \times \text{HerdSizeFactor}(A) \times (\text{probability of infection at 1 km})^{\text{distance from } A \text{ to } B} \times \text{HerdSizeFactor}(B)$
 If a within-unit prevalence chart has not been specified for the source unit production type, that term is dropped from the calculation.
 - iv. Generate a random number r in $[0,1)$.
 - v. If $r < P$, turn B Latent after a delay.

Where

$\text{DistanceFactor}(A,B) = (\text{maximum distance of spread} - \text{distance from } A \text{ to } B) / (\text{maximum distance of spread} - 1)$

$\text{HerdSizeFactor}(A) = (\text{area under histogram of unit sizes from 0 to size of } A) \times 2$

The distance between lat_1, lon_1 and lat_2, lon_2 is approximated as before. The direction from lat_1, lon_1 to lat_2, lon_2 is approximated with the inverse tangent using the same x and y .

Airborne spread can occur from and to quarantined units.¹

Airborne exposures cannot be traced.

Parameters for airborne spread

Parameters for each pair of production types:

- probability of infection at 1 km from source (Infectious Subclinical or Infectious Clinical unit)
- dropoff (linear or exponential)
- wind direction, given as a range (*start* and *end*) in degrees
- maximum distance of spread (applies only to linear dropoff) (km)
- airborne transport delay (days) 

The parameters are given separately for spread in each direction between each pair of production types. That is, the parameters for spread from pig herds to cattle herds can be different from the parameters for spread from cattle herds to pig herds, to account for potential differences in amount of virus produced and/or different minimum-infective-doses for animals in different production-types.

¹See section A7.1. Quarantine for a description of quarantine.

Appendix A. NAADSM model description

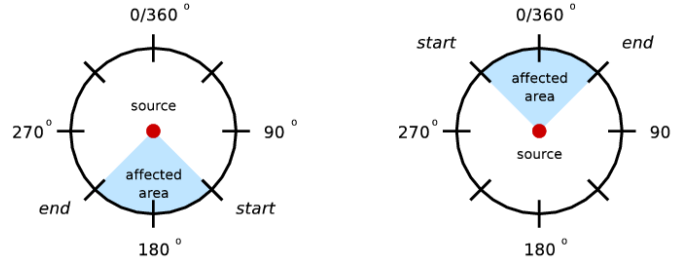

Figure A4-5. Example parameters for north winds (left) and south winds (right).

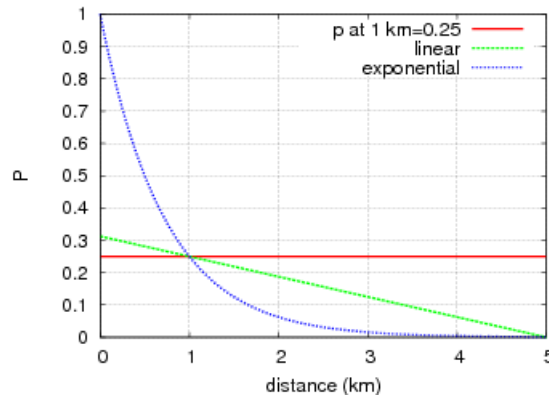

Figure A4-6. Examples of linear and exponential droppoff.

A5. Detection

The simulation of detection works as follows:

On each day,

1. Look up the probability that a farmer or attending veterinarian, for example, will report signs of disease to authorities based on the number of days since the first detection in the population. A nonzero static probability represents the baseline before the first detection.
2. For each Infectious Clinical unit,
 - (a) Look up the probability of observing clinical signs of disease based on the number of days the unit has been Infectious Clinical.
 - (b) If the unit is not inside a zone focus,
 - i. Compute the overall probability of detection as

$$P = (\text{probability of observing clinical signs of disease}) \times (\text{probability of reporting})$$
 Go to step d.
 - (c) If the unit is inside a zone focus,
 - i. Compute the overall probability of detection as

$$P = (\text{probability of observing clinical signs of disease}) \times (\text{zone multiplier})$$

Note that the probability of reporting is assumed to be 1 inside a zone focus, so that value drops out of the calculation.

- (d) Generate a random number r in $[0,1)$.
- (e) If $r < P$, then the diseased unit is detected.

There are no false-positive detections.

A report is immediately known to the authorities.

Probability of observing clinical signs

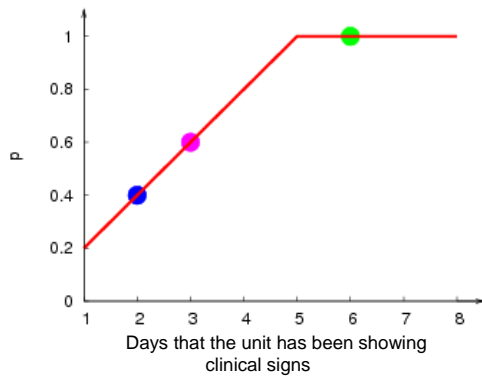

Probability of reporting units with observed clinical signs

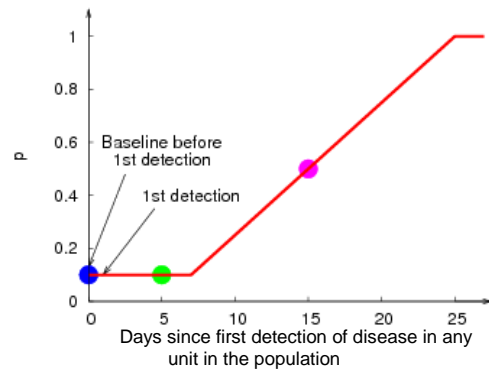



Figure A5-1. Probability of observing clinical signs and reporting units with observed clinical signs is found by two charts. In this example,

- before 1st detection, 2nd day of clinical signs, overall probability of detection = $0.4 \times 0.1 = 0.04$
- 5 days since 1st detection, 6th day of clinical signs, overall probability of detection = $1 \times 0.1 = 0.1$
- 15 days since 1st detection, 3rd day of clinical signs, overall probability of detection = $0.6 \times 0.5 = 0.3$

Detection parameters

Parameters for each production type:

- probability of observing clinical signs of disease vs. days the unit has been Infectious Clinical 
- probability of reporting a unit with observed clinical signs of disease vs. days since the first detection of disease in any unit in the population 

Parameters for each combination of production type and zone:

- multiplier for probability of observing clinical signs

The parameters are given separately for each production type, to account for the possibility that clinical signs of disease may be more obvious in animals of certain production-types, e.g., clinical signs may be reported more rapidly in intensive swine production systems versus cow-calf operations on pastures. The multiplier for the probability of observing clinical signs in units inside a zone focus allows for the simulation of greater vigilance in higher-level zones (see section A7.4. Zones).

A6. Surveillance

Surveillance in the model refers to the process of identifying units at high risk for disease based upon exposure or (potentially) proximity to infected, detected units. Units identified by surveillance will be quarantined and thus can no longer spread disease by direct contact (see section A7.1. Quarantine).

Surveillance does not affect disease detection: that is, units subject to surveillance which become infected are no more likely to be detected than other units of the same production type.

A6.1. Trace surveillance

Units that have had contact with diseased units within a given number of days prior to detection of the diseased unit may be identified by trace investigations. Units subjected to surveillance will be quarantined. Optionally, units identified by trace surveillance may be preemptively destroyed (see section A7.2. Destruction).

Trace-investigations are immediate. Tracing goes one level forward, that is, it identifies units that were recipients of direct or indirect contact from infected, detected units. Tracing does not identify contacts that led to the infection of infected, detected units (Figure A6-1).

Trace surveillance parameters

Parameters specified separately for every production type:

- probability of a trace-out investigation succeeding when direct contact has occurred
- period of interest for trace-out investigations of direct contacts
- probability of a trace-out investigation succeeding when indirect contact has occurred
- period of interest for trace-out investigations of indirect contacts

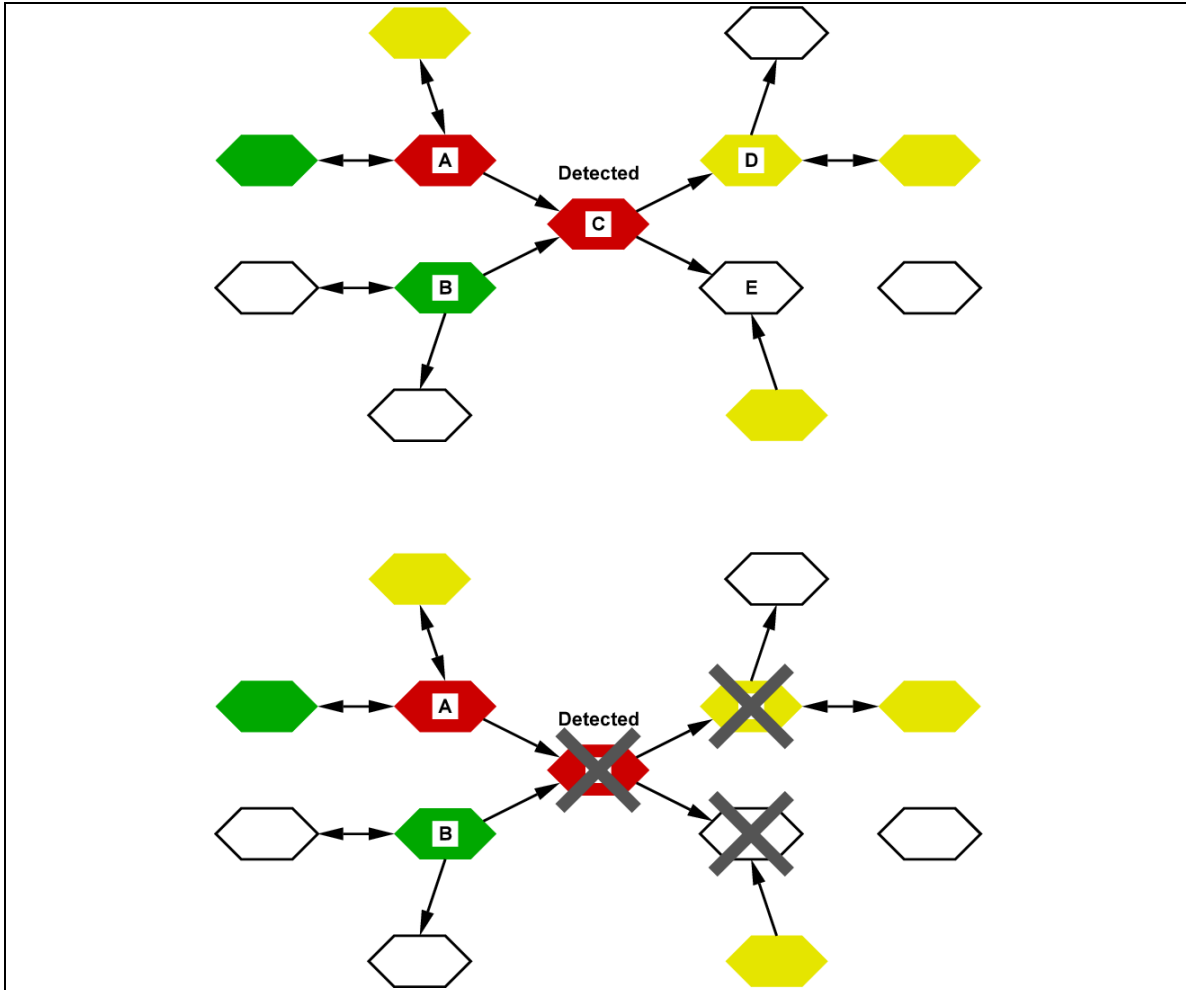

Figure A6-1. Trace out. When unit C is detected, units to which C has shipped animals or sent people or equipment are quarantined and may be marked for destruction. The trace does not extend further, e.g., to units that shipped animals to C (A or B), or units that received animals from D.

A7. Control measures

A7.1. Quarantine

A diseased unit is quarantined on the day immediately following its detection. Units are also quarantined when they are placed on the prioritized waiting list for destruction (see section A7.2.2. Destruction priorities). Quarantined units cannot be involved in direct contact, but indirect contact and airborne spread may still occur to or from a quarantined unit.

A7.2. Destruction

When the first detection occurs in the study population, the authorities may initiate a destruction program. It may take several days before the authorities are ready to begin destroying.

Detected units may be marked for destruction. Units that have had contact with diseased units within a given number of days prior to detection of the diseased unit (found through trace-investigations: see section A6.1. Trace surveillance) and units within a given distance of diseased units may also be marked for destruction. The destruction of these units associated by trace or distance has been called pre-emptive or dangerous-contact slaughter.

A production-type-specific parameter determines whether detection of an infected unit of a particular production type will trigger the formation of a destruction ring or not: for example, detection of an infected swine unit might lead to the destruction of surrounding units of various production types, while detection of an infected sheep unit might not trigger destruction of surrounding units.

A production-type-specific parameter also governs whether units of a particular production type are included in a destruction ring. For example, dairy cattle units might be destroyed in response to the detection of a diseased unit nearby, while sheep units might not be destroyed.

Destruction parameters

Global parameters (applied to all production types):

- delay to begin a destruction program (days)
- destruction capacity vs. days since the first detection (units per day)  (see section A7.2.1. Destruction capacity)
- destruction priorities (see section A7.2.2. Destruction priorities)

Parameters specified separately for every production type:

- indication of whether detection of units of the production type will trigger a destruction ring (yes/no)
- radius of destruction ring (km) , if units of the production type will trigger a destruction ring
- indication of whether units of the production type will be destroyed in response to detection of nearby units (yes/no)
- indication of whether units of this production type identified by trace surveillance after direct contact will be destroyed (yes/no)
- indication of whether units of this production type identified by trace surveillance after indirect contact will be destroyed (yes/no)

A7.2.1. Destruction capacity

There is a limit (called destruction capacity) on how many units can be destroyed per day. Destruction capacity does not consider unit size (*i.e.* the number of animals in each unit). Destruction capacity is specified as a relational chart of the number of units which can be destroyed per day versus the number of days since the first detection of disease. A single destruction capacity applies to units of all production types: for example, if the destruction capacity on a given day is 10 units, then 10 beef units may be destroyed on that day, or 10 swine units, or six units of one and four of the other, depending on the assigned destruction priorities (see section A7.2.2. Destruction priorities).

A7.2.2. Destruction priorities

If a unit is marked for destruction but cannot be destroyed immediately, it is quarantined and goes onto a prioritized waiting list.

There are three criteria which may be used to set destruction priorities: the production type of the unit, the reason for destruction of the unit, and the number of days a unit has been waiting in the destruction queue. Within the production type criterion, the production types present in a scenario are further prioritized (*e.g.* cattle may have a higher destruction priority than swine, or *vice versa*). Similarly, within the action reason criterion, the reasons for destruction are further prioritized: these reasons are detection of disease, exposure by direct contact, exposure by indirect contact, and presence within a specified destruction ring. For example, cattle herds that are marked for destruction because they were detected as diseased may have a higher priority than cattle herds that are marked for destruction because they are near a diseased unit.

The order in which the three criteria are applied must be specified in each scenario. For example, the number of days a unit has been in the destruction queue may be the overriding priority, so that units of any production type, holding for any reason, that have

Appendix A. NAADSM model description

been holding for the longest period of time are destroyed before any others. Criteria with the highest priority are applied first. In the event that two units are encountered that have the same priority based on the top criterion, subsequent criteria are applied (see examples below).

No two production-type/reason for destruction combinations can have the same priority. That is, cattle herds that were detected as diseased *must* have a strictly higher priority than pig herds that were detected as diseased (or *vice versa*), and cattle herds that were detected as diseased *must* have a strictly higher priority than cattle herds that were simply near to a detected unit (or *vice versa*).

No distinction in destruction priority is made based on source of exposure: cattle herds that have been exposed by a swine herd, for example, are treated no differently than cattle herds exposed to infection by other cattle herds.

On each day, the authorities destroy as many units as possible (up to the destruction capacity for that day) from the destruction queue, beginning with the highest priority.

Examples of destruction priorities

Consider the following examples, using these four units which have been designated for destruction:

- Unit A. Cattle herd, detected infection, holding for 3 days
- Unit B. Cattle herd, indirect contact, holding for 5 days
- Unit C. Swine herd, direct contact, holding for 1 day
- Unit D. Swine herd, within circle/ring, holding for 5 days

Example 1:

With the following destruction priorities:

Days holding > production type (swine > cattle) > destruction reason (detected > direct > indirect > circle/ring)

The four herds are destroyed in the following order:

D, B, A, C

Example 2:

Priorities: production type (cattle > swine) > destruction reason (detected > direct > indirect > circle/ring) > days holding:

Destruction order: A, B, C, D

Example 3:

Priorities: production type (cattle > swine) > days holding > destruction reason (detected > direct > indirect > circle/ring):

Destruction order: B, A, D, C

Example 4:

Priorities: destruction reason (detected > circle/ring > direct > indirect) > production type (cattle > swine) > days holding:

Destruction order: A, D, C, B

A7.3. Vaccination

When the disease is detected, authorities may also initiate a vaccination campaign. This consists of vaccinating units within a specified distance of the detected units – in circles or rings around detected units. A production-type-specific parameter determines whether detection of an infected unit of a particular production type will trigger the formation of a vaccination ring or not: for example, detection of an infected swine unit might lead to the vaccination of surrounding units of various production types, while detection of an infected sheep unit might not trigger vaccination of surrounding units.

A production-type-specific parameter also governs whether units of a particular production type are included in a vaccination program. For example, dairy cattle units might be vaccinated in response to the detection of a diseased unit nearby, while sheep units might not be vaccinated.

The initiation of a vaccination program may be delayed until a certain trigger point is reached in terms of numbers of detected units (see section A7.3.1. Initiation of a vaccination program)

If a unit is marked for vaccination but cannot be vaccinated immediately, it goes onto a prioritized waiting list (see sections A7.3.2. Vaccination capacity and A7.3.3. Vaccination priorities).

For a unit to receive multiple vaccinations, vaccination of that individual unit must be triggered multiple times (see section A7.3.4. Minimum time between vaccinations). It is not currently possible to schedule revaccination of units without an additional trigger.

Vaccination program parameters

Global parameters (applied to all production types):

- number of detected units before vaccination begins (see section A7.3.1. Initiation of a vaccination program)
- vaccination capacity vs. days since the first detection (units per day)  (see section A7.3.2. Vaccination capacity)
- vaccination priorities (see section A7.3.3. Vaccination priorities)

Parameters set individually for each production type:

- indication of whether detection of units of the production type will trigger a vaccination ring (yes/no)
- radius of vaccination ring (km) , if units of the production type will trigger a vaccination ring
- indication of whether units of the production type will be vaccinated in response to detection of nearby units (yes/no)
- minimum time between vaccinations (days) , if units of the production type will be vaccinated (see section A7.3.4. Minimum time between vaccinations)

A7.3.1. Initiation of a vaccination program

A vaccination program is initiated when the user-specified number of infected units has been detected. Until or unless this number is reached, units are not marked for vaccination. Once this critical number has been reached, units within the specified vaccination ring surrounding the most recently detected unit are marked for vaccination. Vaccination rings also will be created around any unit that is detected on the same simulation day that the critical number is reached. Similarly, vaccination rings will be created around infected units detected on subsequent simulation days. Units marked for vaccination are then treated according to the steps described below.

A7.3.2. Vaccination capacity

Vaccination capacity (the number of units which can be vaccinated per day) is handled in the same way as destruction capacity (see section A7.2.1. Destruction capacity), and is specified as a relational chart of the number of units which can be vaccinated per day versus the number of days since the first detection of disease. Vaccination capacity does not consider unit size (*i.e.* the number of animals in each unit). A single vaccination capacity applies to units of all production types.

Personnel for destruction cannot be temporarily loaned to vaccination teams, or *vice versa*, during a simulation run. In other words, the daily limits for destruction and vaccination operate independently of one another.

A7.3.3. Vaccination priorities

If a unit is marked for vaccination but cannot be vaccinated immediately, it goes onto a prioritized waiting list.

Vaccination priorities are set in fashion similar to destruction priorities (see section A7.2.2. Destruction priorities). There are two criteria which may be used to set vaccination priorities for units which fall within a vaccination circle. These criteria are the production type of the unit and the number of days that a unit has been in the vaccination queue. Within the production type criterion, the production types present in a scenario are further prioritized.

The order in which these two criteria are applied must be specified in each scenario. For example, the number of days a unit has been in the vaccination queue may be the overriding priority, so that units of any production type that have been holding for the longest period of time are vaccinated before any others. The criterion with the highest priority is applied first. In the event that two units are encountered that have the same priority based on the top criterion, the next criterion is applied.

A7.3.4. Minimum time between vaccinations

The minimum time between vaccinations is the number of days which must pass before a unit may be revaccinated. Once the specified number of days has passed, a unit may be revaccinated if vaccination of that unit is triggered again.

Consider the simple situation involving units *A*, *B*, and *C* as shown Figure A7-1. Disease is detected in unit *A* ten days before disease is detected in unit *C*. Both detections trigger vaccination circles as shown.

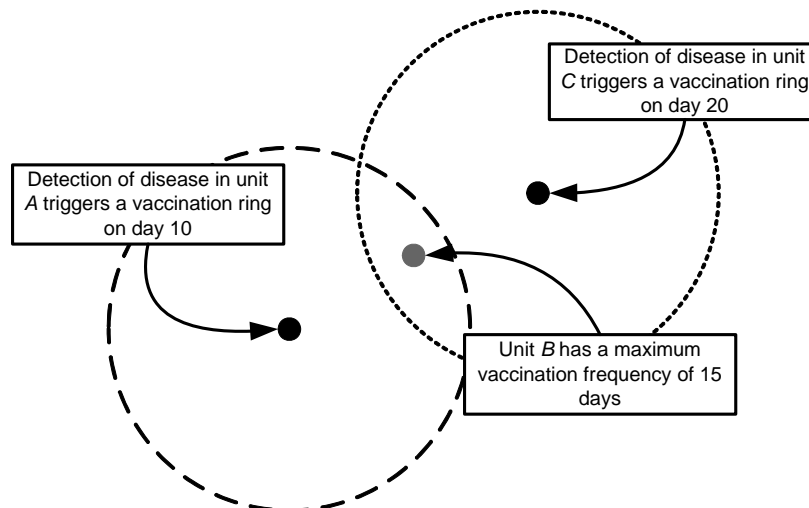

Figure A7-1. Overlapping vaccination rings. See text for description of timing of vaccinations.

Appendix A. NAADSM model description

Unit *B* is within vaccination circles triggered by detection of units *A* and *C*, and will be added twice to the queue of units to be vaccinated. If there is no waiting period for vaccination (*i.e.* vaccination capacity is not reached), unit *B* will receive only one vaccination: its minimum time between vaccinations will not have been reached before it comes to the head of the queue the second time.

If vaccination capacity has been reached, unit *B* will receive two vaccinations only if the elapsed time between the first and second scheduled vaccinations exceeds the unit's minimum time between vaccinations. This subsequent vaccination resets the vaccine-immune period for unit *B*. If the elapsed time is less than the unit's maximum vaccination frequency, unit *B* will not be revaccinated.

A7.4. Zones

Zones are areas of differing surveillance and control policies. This section describes how zones are established; see also sections A4. Spread and A5. Detection for a discussion of how zones affect movement and detection, respectively.

There can be an arbitrary number of zones, each with a unique name. The basic form of a zone is a circle around a unit. Higher levels of surveillance correspond to smaller circles. Areas outside the circle also constitute a zone, with the lowest surveillance level (figure A7-2).

A “focus” of a zone can be established around any unit that is detected as diseased. A focus can also be established around any “dangerous contact” unit that has been discovered through tracing (see section A6.1. Trace surveillance). The number and size of zone rings established is always the same and does not depend on the production type of the unit that caused the zone focus (figure A7-3).

Overlapping foci of the same zone merge (figure A7-4). Zones with lower surveillance levels are absorbed when enclosed by a zone of a higher surveillance level (the “no donuts” rule, figure A7-5).

Zone parameters

Parameters set individually for each zone:

- name
- radius (km)

Parameters set individually for each production type:

- indication of whether detection of diseased units of the production type will create a zone focus (yes/no)
- indication of whether traced “dangerous contacts” of this production type will create a zone focus (yes/no)

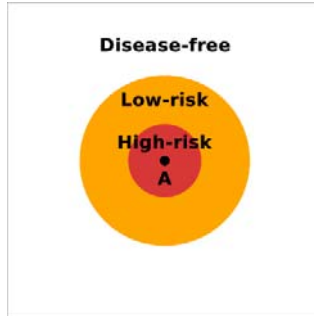

Figure A7-2. A focus with 2 zones established around it.

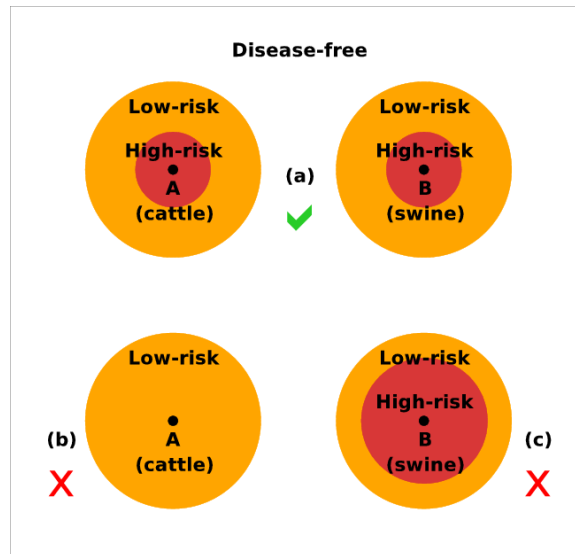

Figure A7-3. Zones are triggered uniformly, regardless of the production types which triggered the zone focus (a). It is not possible to trigger only selected zones (b) or zones of different sizes (c) around different production types.

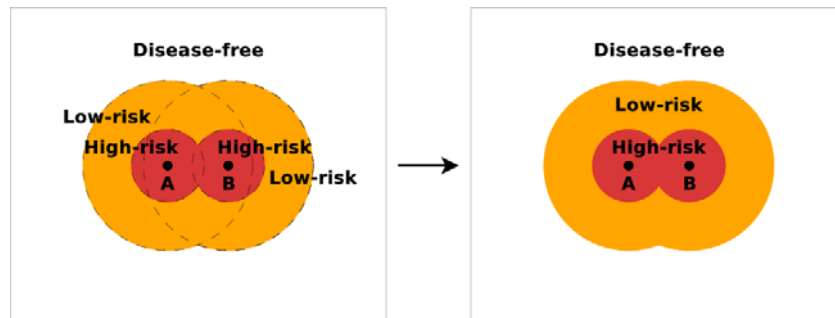

Figure A7-4. Overlapping foci of the same zone merge.

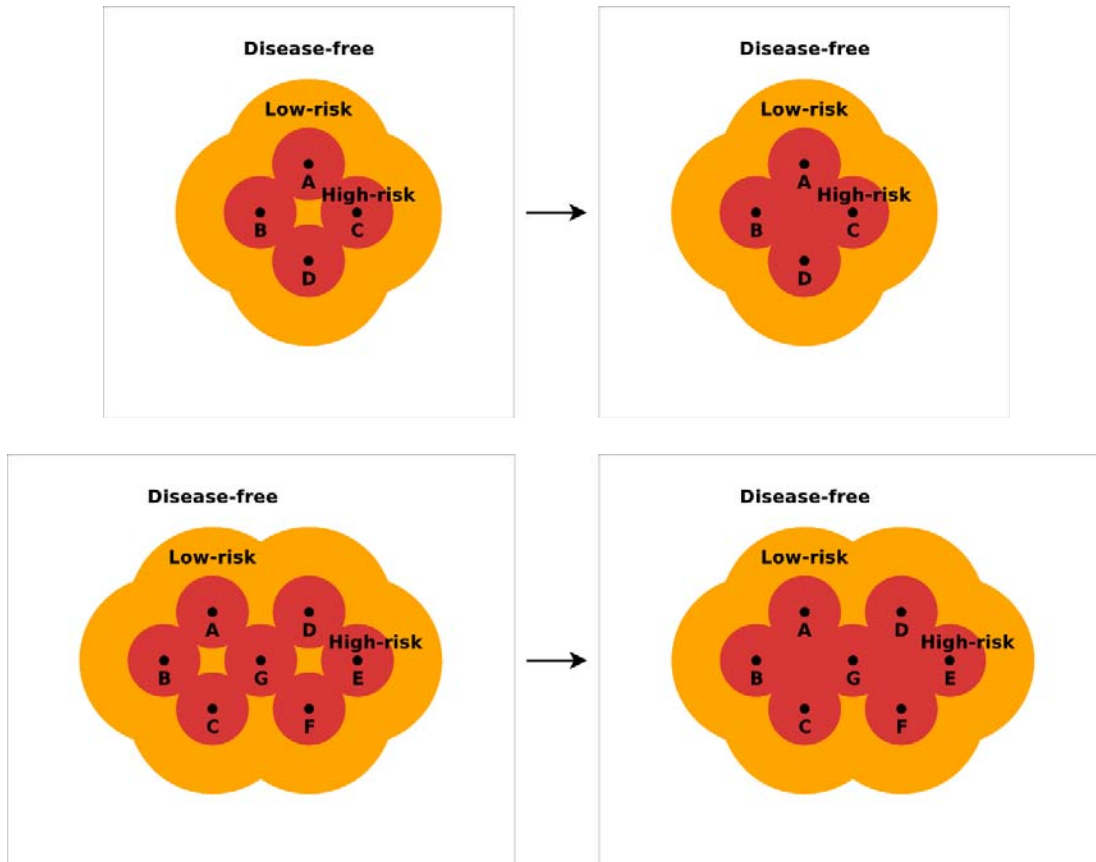

Figure A7-5. Enclosed areas of a lower surveillance level are absorbed. Note that adding a new focus (G) can create more than one enclosed area that must be absorbed.

A8. Biological effects of vaccination

When a unit is vaccinated, it remains Susceptible for a time while immunity develops, then becomes Vaccine Immune. The length of the immune period is determined stochastically for each new vaccination. After the immune period, the unit reverts to a Susceptible state.

If a unit is infected after being vaccinated but before turning Vaccine Immune, the effects of the vaccination are cancelled.

Vaccinating a unit that is not Susceptible has no effect on its disease state.

Parameters for effects of vaccination

Parameters specified for each production type:

- delay to produce immunity (days)
- immunity period (days) 

The parameters are given separately for each production type.

A9. Priorities of action

Because the events in one simulation day could be considered to happen simultaneously, and because different processes may try to make conflicting changes to a unit, there is a need to order or prioritize the processes.

The ordering is:

1. Infection, destruction, or vaccination
2. Biological processes happening within units

(Note that these correspond to the transition labels in Figure A2-1.)

If a unit is both infected or vaccinated, or infected and destroyed, the order in which these happen is chosen randomly. If a unit is to be vaccinated and destroyed on the same day, destruction will always have precedence. If all three are scheduled to occur on the same day, a unit may or may not be infected before it is destroyed, but it will never be vaccinated.

If two or more processes infect the same unit on the same day, one process is chosen randomly as the cause of the infection, for the purpose of reporting in simulation statistics. Similarly, if there are two or more reasons for vaccinating or destroying a unit, one reason is chosen randomly for the purpose of reporting.

Some examples illustrating the effects of this ordering:

- If unit *A* is due to change from Susceptible to Vaccine Immune on day *D*, and a shipment of infectious animals arrives on day *D*, *A* is infected. (The exposure happens “before” the natural progression to Vaccine Immune.)
- If unit *A* is due to change from Vaccine Immune to Susceptible on day *D*, and the wind carries virus from an infectious unit on day *D*, *A* is not infected. (The exposure happens “before” the natural progression to Susceptible.)
- If unit *A* is destroyed on day *D*, and the wind carries virus from an infectious unit on day *D*, *A* may be reported in simulation statistics as having been an infected unit or a healthy unit. (Whether the infection happens “before” the destruction is determined randomly.)

A10. Costs

Direct costs associated with destruction and vaccination during an outbreak may be calculated. If zones are used, direct costs associated with surveillance within zones may also be determined.

A10.1. Costs associated with destruction

There is a fixed cost associated with appraisal of each destroyed unit, regardless of the number of animals in the unit. The cost associated with cleaning and disinfection each unit is also fixed regardless of the number of animals in each unit.

Beyond these fixed per-unit costs, the per-animal costs for euthanasia, carcass disposal, and indemnification apply.

The total cost of destruction *for each unit* of a particular production type is calculated as follows:

$$\begin{aligned} & (\text{Appraisal cost} + \text{Cleaning and disinfection cost}) \\ & + [(\text{Number of animals in the unit}) \times (\text{Cost of euthanasia} + \text{Cost of indemnification} + \text{Cost of disposal})] \end{aligned}$$

The total cost of destruction *for each production type* is calculated as:

$$\begin{aligned} & (\text{Number of units destroyed}) \times (\text{Appraisal cost} + \text{Cleaning and disinfection cost}) \\ & + [(\text{Total number of animals destroyed}) \times (\text{Cost of euthanasia} + \text{Cost of indemnification} \\ & \quad + \text{Cost of disposal})] \end{aligned}$$

Parameters for destruction costs

Parameters specified for each production type:

- Appraisal cost **per unit**
- Cost of cleaning and disinfection **per unit**
- Cost of euthanasia **per animal**
- Cost of indemnification **per animal**
- Cost of carcass disposal **per animal**

A10.2. Costs associated with vaccination

There is a fixed cost associated with vaccination set up for each vaccinated unit, regardless of the number of animals in the unit. The cost of vaccination of each animal in the unit is added to this fixed unit cost.

The cost of vaccination of each animal will depend on the total number of animals vaccinated. For each animal up to a specified threshold, only a baseline vaccination cost applies. For each animal over this threshold, an additional cost applies.

The total cost of vaccination *for each production type* is calculated as follows:

If the threshold is not reached:

$$\begin{aligned} &[(\text{Number of units vaccinated}) \times (\text{Cost of site setup})] \\ &+ [(\text{Total number of animals vaccinated}) \times (\text{Baseline cost per animal})] \end{aligned}$$

If the threshold is reached:

$$\begin{aligned} &[(\text{Number of units vaccinated}) \times (\text{Cost of site setup})] \\ &+ [(\text{Threshold level}) \times (\text{Baseline cost per animal})] \\ &+ [(\text{Total number of animals vaccinated} - \text{Threshold level}) \times (\text{Baseline cost per animal} \\ &\quad + \text{Additional cost per animal})] \end{aligned}$$

Parameters for vaccination costs

Parameters specified for each production type:

- Number of animals of this production type that can be vaccinated before the cost of vaccination increases
- Baseline cost of vaccination **per animal** (this cost applies until the specified threshold has been met)
- Additional cost of vaccination **per animal** for each animal beyond the specified threshold
- Cost of vaccination site setup **per unit**

A10.3. Costs associated with zone surveillance

For each animal within a particular zone (see section A7.4. Zones), there is a daily cost associated with enhanced surveillance, diagnostic testing, and any other special activity that might occur within that zone.

The length of time that an individual unit – and animals within that unit – spends in a zone is the number of days from the time that the zone focus is established, until the time that at least one of the following three conditions is met: 1) the zone that the unit is in changes, *e.g.*, as a result of merging of zones or the creation of a new zone focus; 2) the unit is destroyed; or 3) the outbreak ends and all disease control measures are complete.

For each unit of a particular production type in a particular zone, the number of “animal days” spent in the zone is calculated as follows:

$$\begin{aligned} (\text{Animal days for a unit in a zone}) = \\ [(\text{Number of days that the unit is in the zone}) \times (\text{Number of animals in that unit})] \end{aligned}$$

For the production type, the number of animal days spent in the zone is the sum of the number of animal days for each unit of that type in the zone:

Appendix A. NAADSM model description

$$(\text{Animal days for a production type for a zone}) = \sum_{i=1}^n (\text{Animal days for unit}_i \text{ in a zone})$$

Where n is the number of units of the production type in the zone

The total cost of zone surveillance for the production type in the zone is calculated as shown below:

$$\begin{aligned} (\text{Cost of surveillance of a production type in a zone}) = & \\ & [(\text{Animal days for a production type for a zone}) \\ & \times (\text{Cost of surveillance in the zone, per animal of the production type, per day})] \end{aligned}$$

From the costs of surveillance for each production type for each zone, other totals (*e.g.*, the cost of surveillance of a particular production type across all zones) can be calculated.

Parameters for surveillance costs

Parameters for each combination of production type and zone:

- Cost of surveillance **per animal** per day